

COMPANY / CONTRACTOR HOME / PROJECT OWNER

COMPANY / CONTRACTOR / CUSTOMER NAME

PHONE _____ FAX _____ EMAIL _____

CONTACT NAME _____ TAG (IF COMPANY) _____

PROJECT LOCATION - STREET ADDRESS

PROJECT LOCATION - CITY

BUILDING TYPE

RESIDENTIAL COMMERCIAL AGRICULTURAL

Note: Building type is determined by the use of the building and the Ontario Building Code or National Building Code. If you are unsure, please contact your local building department.

PROJECT DESCRIPTION

NEW CONSTRUCTION GARAGE / SHED ADDITION / RENOVATION

FARM BUILDING COMMERCIAL BUILDING

OTHER _____

ARE YOU MATCHING AN EXISTING BUILDING? YES NO

COMMENTS

PAGE 2 OF 4

ROOF STYLE

	PLAN	ELEVATION	3D
GABLE / COMMON <input type="radio"/>			
COTTAGE / HIP <input type="radio"/>			
DUTCH <input type="radio"/>			

BUILDING DIMENSIONS

A _____ FT _____ INCHES (TRUSS DIRECTION - SEE DIAGRAM BELOW)

B _____ FT _____ INCHES

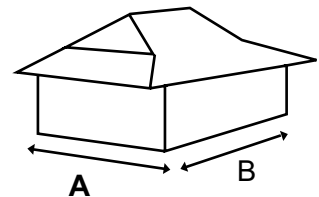
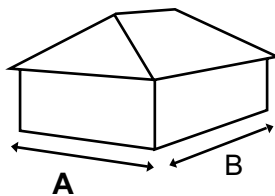
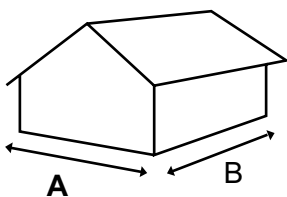

ROOF PITCH

ROOF PITCH _____ /12

SEE DIAGRAM TO THE RIGHT

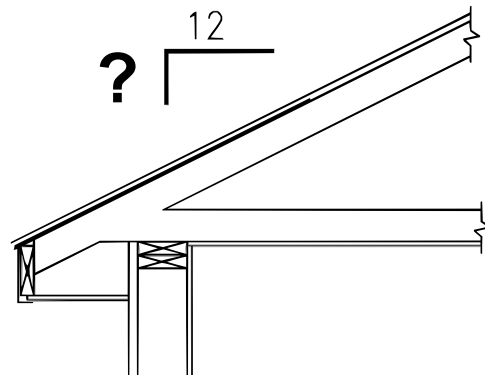

PAGE 3 OF 4

OVERHANG

CHOOSE LENGTH OF OVERHANG

8" 12" 16" 18" 24"

OTHER _____

Note: Overhang size is finished and includes 1.5" fascia board.
Example: 12" overhang, 10.5" on truss plus 1.5" fascia = 12".

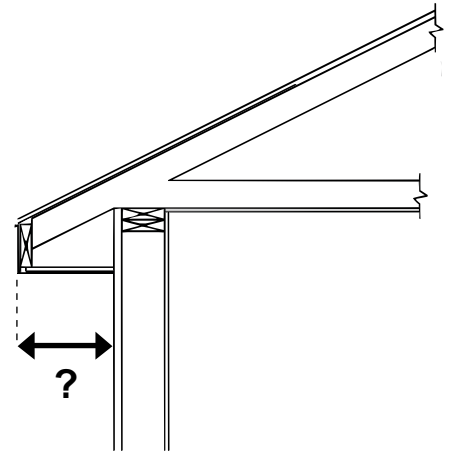

TRUSS SPACING

16" O.C. 24" O.C. 48" O.C. OTHER _____

Maximum spacing for residential application is 24" O.C.

WALL DETAILS

WALL HEIGHT _____ FT _____ INCHES

CHOOSE BEARING SIZE

2 x 4 2 x 6 OTHER _____ (POLE STRUCTURE)

EXTERIOR FINISH

BRICK SIDING STUCCO OTHER _____

CEILING DETAILS

CHOOSE A CEILING TYPE

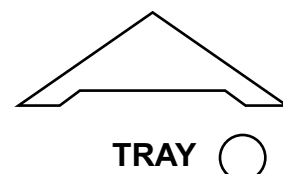
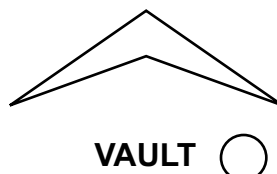
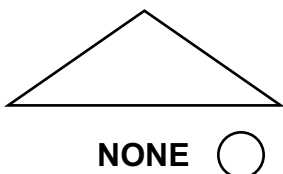

STORAGE

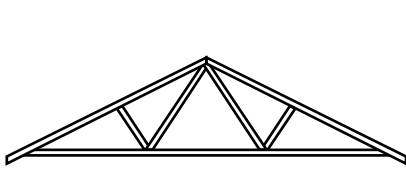

NONE

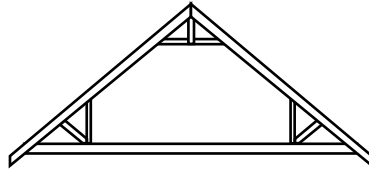

ATTIC TRUSS

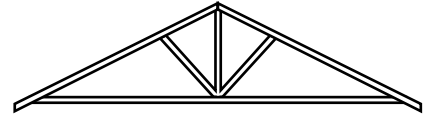

BOTTOM CHORD

ADDITIONAL NOTES:

DJ JACKSON'S WORKS HARD TO ACCOMMODATE ALL CUSTOMERS IN BOTH THEIR PRICING AND CONSTRUCTION PHASES. IN MOST CASES, WE WILL RETURN GARAGE AND BASIC ADDITION QUOTATIONS WITHIN 1 - 2 BUSINESS DAYS. IN ANY CASE WHERE ADDITIONAL TIME IS REQUIRED YOU WILL BE CONTACTED BY EMAIL WITH THE EXPECTED ARRIVAL DATE OF YOUR QUOTATION.

OUR COMPANY RUNS YEAR ROUND WITH A LEAD TIME OF 2-3 WEEKS FROM DATE OF ORDER TO DATE OF DELIVERY. IF YOUR PROJECT REQUIRES EITHER MORE OR LESS TIME, WE WOULD BE HAPPY TO DISCUSS MAKING SPECIAL ARRANGEMENTS.

